

LED BACK-LIT PANEL

Using TV backlight technology, PMMA lens, No yellowing risk

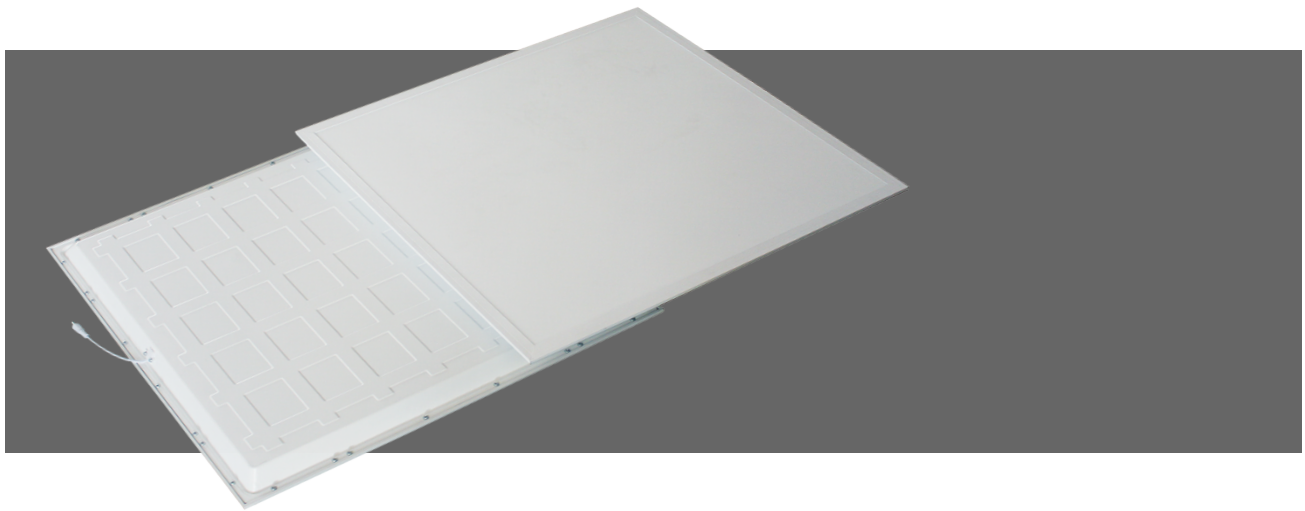

ERP

230V

No
Flicker

Guarantee
5 Years



1.Features

- The idea replacement solution for economic edge-lit panel.
- Direct lighting without LGP to avoid yellowing.
- As a consumption design panel light, offer much more competitive.
- Product automatic protection(OVP OLP OTP OCP).
- Suspension, wall mounted, and spring mounted for convenient installation and maintenance.

2.Application

COMMERCIAL LIGHTING

Restaurant
Hotel
Office
Hospital
Supermarkets
Shopping mall
School
Etc

PUBLIC LIGHTING

Airports
Train stations
Theatres
Museums
Indoor stadium
Government building
Etc

INDUSTRIAL LIGHTING

Manufacture
Warehouses
Exhibition centers
Gas stations
Toll stations
Gymnasium
Etc

3.Product Dimension

Model NO.	Size A(mm)	Size B(mm)	Size C(mm)
MYDP-6060-30W	595	595	32

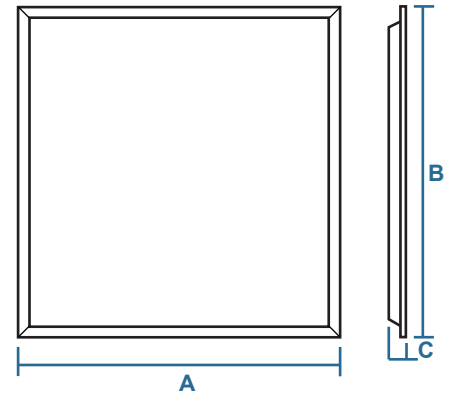

■ Light Distribute Curve

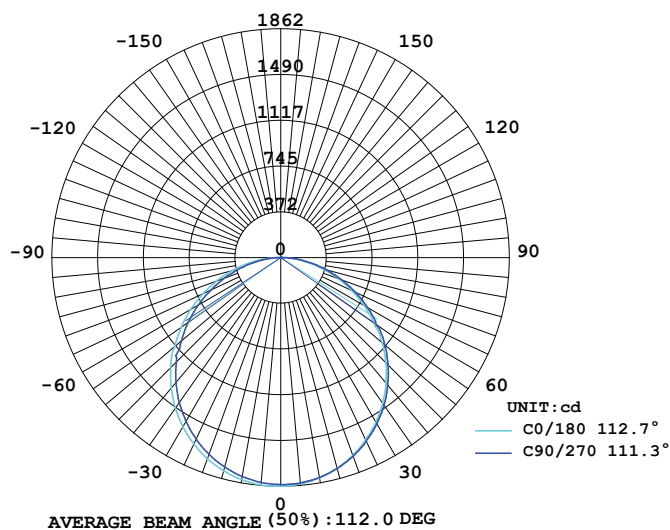

4.Parameters

MODEL No.	MYDP-6060-22W
OPTICAL PARAMETERS	
Wattage	22W
Beam Angle	112°
Input Voltage	220V~240 VAC
Power Factor	>0.9
Luminous Flux	4400LM
CCT	4000K/6500K
CRI	>80 Ra
Efficacy	200lm/W
Case Temperature	<65 °C @ 25 °C
Working Temperature	-10~40 °C
Storage Temperature	10~50 °C
Storage Humidity	20~60%
Chips Type	2835 9V
Life Span	>50000 hours
Warranty	5years

5.Packing Details

Version	Package	Quantity	Packing Dimension	N.W.(KGS)	G.W.(KGS)
MYDP-6060-22W	Engineering Packing	6pcs	650*270*670mm	9	11

